



- cooling / heating output
- fan
- defrost
- alarm
- Eco** Eco Mode

Buttons explanation

- Press Info / setpoint adjustment
- button parameter up / ECO mode
- button parameter down / press 2 sec for manual defrost
- button back / standby

Display messages during normal operation

- HC** high temperature at condenser
- OFF** standby
- CL** request the condenser cleaning
- DO** alarm for open door
- HI / LO** over / under temperature alarm in the cell of
- E1...3** error of sensor T1...3
- ALR** alarm

Display messages in the Info menu

- T1** temperature of probe T1
- T2** temperature of probe T2
- T3** temperature of probe T3
- THI** maximum temperature probe T1
- TLO** minimum temperature probe T1
- CND** compressor operating time in weeks
- LOC** keypad lock state

Access to the Info menu

is obtained by pressing the button and then release it. You can switch through the parameters using or and display the value by pressing . You get back to the actual value by waiting 30 seconds or pressing .

CL – reset condenser cleaning

to reset the value press until the display shows CND. Now hold and press simultaneously.

Change of setpoint

To display and change the set point press for at least ½ second. To change the setpoint, hold and adjust with or the setpoint. After releasing the button , the desired setpoint is stored.

Caution: The set value can only within the limits of SPL.SPH will be set.

Wiring diagram

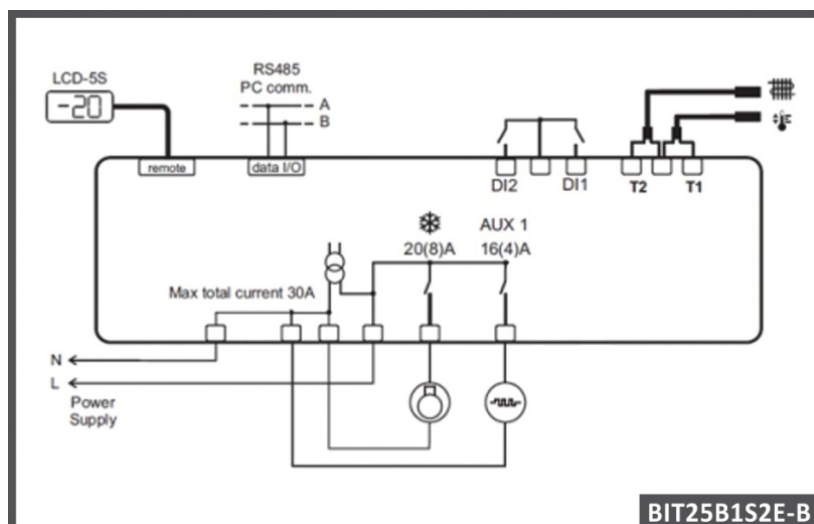

Parameter setting instructions

Kühla Kühltechnik & Ladenbau GmbH

BIT25B1S2E-B Kühla

Parameter list

Parameter	Setting range	Description	Setup Kühla
<i>SPL</i>	-50.SPH °	Minimum set point	1
<i>SPH</i>	SPL... + 110 °	Limit value	15
<i>SP</i>	SPL...SPH °	Setpoint	7
<i>HYS</i>	1.10.0 °	Switching hysteresis	2
<i>CrE</i>	0.30 min	Compressor break	3
<i>Et1</i>	0.30 min	Activation time RL1 fault T1	10
<i>Et2</i>	0.30 min	Stop time RL1 fault T1	5
<i>ESd</i>	0.30 min	Delay compressor stop at Door open / DS only = YES	0
<i>dFi</i>	NON / TIM / FRO	Start mode of defrost, NON = no defrost TIM = defrost timer FRO = defrost about maturity approach	TIM
<i>dFt</i>	0.99 h	Timer value up to the next defrost	8
<i>dFb</i>	NO. / YES	Storage timer value during voltage failure	YES
<i>dL1</i>	-50.. + 110 °	Temperature defrost	10
<i>dto</i>	1.120 min	Maximum defrost duration	30
<i>dEY</i>	OFF / ELE / GAS	Defrost type	OFF
<i>dPd</i>	0.240 sek	Evaporator-pump-down	0
<i>dri</i>	0.30 min	Dripping time after defrost	2
<i>ddi</i>	RT / LT / SP / DEF	Display display when defrost RT = actual temperature LT = final temperature before defrost start SP = setpoint display DEF = display "DEF" during defrost	SP
<i>ddy</i>	0.60 min	While timing + after the defrost	10
<i>Fid</i>	NO. / YES	Fan activation during defrost	YES
<i>Fdd</i>	-50.. + 110 °	Temperature restart evaporator fan	2
<i>Ft0</i>	0.120 min	Max evaporator fan stop after defrost	4
<i>FEi</i>	NON / TMP / TIM	Control evaporator fan in thermal control NON = always a fan TMP = compressor running TIM = timing	NON
<i>iUFE1</i>	-12.0...0.0 °	Difference evaporator air to the fan stop	-
<i>FdH</i>	1.0...12.0 °	Temperature-differential to the reset function	-
<i>Ft1</i>	0.180 sek	Switch-off delay fan by compressor stop	-
<i>Ft2</i>	0.30 min	Fan stop with timer	-
<i>Ft3</i>	0.30 min	Fan operating with timer	-
<i>REi</i>	NON / ABS / REL	Alarm type NON alarms = disabled ABS = absolute alarm thresholds REL = relative alarm differentials to the setpoint	REL
<i>RLA</i>	-50.. + 110 °	Lower alarm threshold	-
<i>RHA</i>	-50.. + 110 °	Upper alarm threshold	-
<i>RLr</i>	-12.0°	Lower alarm differential	4
<i>RHr</i>	0... + 12 °	Upper alarm differential	4
<i>RE1</i>	T1 / T2 / T3	Reference sensor for temperature alarms	T1
<i>REd</i>	0.120 min	Temperature alarm delay	90

Parameter	Setting range	Description	Setup Kühla
RdD	0.30 min	Door alarm delay	0
RHi	NON / ALR / STP	Condenser alarm mode NON = alarm disabled ALR = buzzer + display "HC" STP = alarm + compressor and defrost stop	NON
RHt	-50.. + 110 °	Temperature condensing alarm	-
RCC	0.52 Weeks	Message condenser cleaning	26
11 S _i	NON / MAN / DI2	Transition to the 2nd set of parameters NON = disabled MAN = manual toggle button "ECO" DI2 = switchover via digital input DI2	NON
!!!IISL parameter... IIdF are only valid in the ECO mode!			
11 S _L	-50 °...IISH	2. Minimum limit value	1
11 S _h	IISL... + 110 °	2. Limit setpoint	15
11 S _P	IISL...IISH °	2. Target value	7
11 h _Y	1.0...10.0 °	2. Switching hysteresis setpoint	5
11 F _c	NON / TMP / TIM	FCM see control fan	TMP
11 d _F	0.99 h	Timer value up to the next defrost 2 Setup	0
S _b	NO. / YES	Activate stand-by	YES
d i 1	NON / DOR / ALR / RDS	Features digital input 1 NON = disabled DOR = door contact ALR = an alarm occurs when opening RDS = a defrost is performed when closing	NON
d i 2	NON / DOR / ALR / RDS / IISM / T3 / PSP	DI1 see functions digital input 2 IISM = when closing → Transition to the second Setup T3 = function as sensor input T3 PSP = setpoint potentiometer input	NON
t 3 _i	DSP / CND	Function probe T3 DSP display display = temperature T3 CND = condenser temperature measurement	DSP
053	-12, 5... + 12, 5 °	Measurement value correction T3	0
PS _L	-50.. + 70 °	Minimum set value by potentiometer	-
PS _r	0.0...15.0 °	Setpoint range with potentiometer BSP: PSL = 2 and 8 = PSR → Setpoint within 2.0...10.0 ° adjustable	-
PQF	NO. / YES	Stop by a potentiometer, if the Potentio-meter will be minimal → Standstill arrangements	-
L S _i	NON / MAN / D10 / D20 / D2C	Lighting control system NON = disabled MAN = button to display D10 = opening DI1 = lights on D20 = opening DI2 = lights on D2C = close of DI2 = lights on	MAN
0A 1	NON / FAN / DEF LGT / 0-1 / ALO / ALC	Modes of operation AUX output 1 NON = disabled FAN = fan control enabled DEF = enabled for defrost control LGT = enabled for lighting control 0-1 = Relay follow ON/OFF state of the controller ALO = opening contacts in case of an alarm ALC = closing of contacts in case of an alarm	FAN
0A 2	See OA1	Modes of operation AUX output 2, OA1 see !!!Only in version BIT25B1S3E-B!	LGT
05 1	-12, 5... + 12, 5 °	Measurement value correction T1	0
t 2	NO. / YES	Activation T2	NO.
i 2 _{SP}	-12, 5... + 12, 5 °	T2 measurement value correction	0
t L d	1.30 min	Storage interval TLO / TLI	10
S _c L	1 ° C / 2 ° C / ° F	Reading scale	1°
S i i	0.100	Display slow down	0
Rd _r	1.255	Bus address	1